

Design and decision optimization of a robot shuttle system

Wei Wang¹ and Yaohua Wu¹ and Ming Li²
Shandong University, Jinan, China
Shandong Jianzhu University, Jinan, China
Yaohua Wu: ww_sdu@mail.sdu.edu.cn

Abstract: *This paper studies a robot shuttle system (RSS), featured by automated guided vehicles (AGV) transporting storage totes with products in batches to order pickers. A robot shuttle system is a new type of automated material handling system, where products are stored in storage totes, so called totes-to-picker system. We develop a semi-open queueing network model (SOQN) to describe the RSS. The model can be used to effectively estimate system performance in terms of maximum order throughput capacity, order throughput time and resource utilization. Simulation experiments are conducted to validate the analytical model. We then conduct numerical experiments to investigate how the service batch size and the number of AGVs affect system performance. Through experimental results analysis, we provide guidelines on the optimization of these system design and decision related parameters.*

Keywords: *Robot shuttle system, Automated guided vehicles, Material handling system, Queueing network*

1 Introduction

In last decade, the percentage share of e-commerce sales has shown steady growth. Online retailers are facing the challenge of improving delivery speed and reducing overall system costs. Warehouse automation is considered as an effective solution to meet these requirements and has become a popular research topic in material handling ((Baker and Halim, 2007). Since order picking is one of the most critical tasks in warehousing, many automated order picking systems are developed in recent years, such as the robotic mobile fulfillment system (RMFS), and the automated vehicle storage and retrieval system (AVS/RS). The RMFS obtains high flexibility and scalability since it is deployed on the ground and employs movable shelves. However, the RMFS has poor space utilization due to the height limitation of movable shelves, which leads to higher storage costs. Moreover, robots in RMFS do lots of useless delivery. Robots in RMFS transport a pod at a time, while generally only a few products on the pod are required by an order. The robot shuttle system (Figure 1) is a new type of automated order picking system using innovative devices, which can address the above-mentioned issues. In an RSS, dense racks and storage totes (Figure1-b) are used to store products. Besides, it employs picking AGVs equipped with lifts to transport storage totes. As shown in Figure 1-c, there are several storage units and a lift on the AGV. This allows vehicles to transport only what is required according to customer orders. The RSS has been brought to market by companies such as Hai Robotics, Geek+, and Guozi Robotics. It has seen successful implementation in the famous office supplies seller, the Staples.

Compared to RMFS (e.g. Kiva system), the RSS has three main advantages: First, it has higher storage capacity and space utilization due to the use of dense racks and storage totes; Second, the picking vehicles in an RSS transport storage totes in batches to order pickers for order picking, which reduces the times of vehicles' round trips between storage area and workstations. Besides, the batch size can be varied according to real order picking demands. Therefore, the batch service of picking vehicles improve their handling efficiency and operational flexibility.

Third, a tote in RSS only contains one Stock keeping unit (SKU), and picking vehicles only need to bring which are required by customer orders to picking stations. This reduces average picking time of order pickers since they don't need to find required products from a whole pod and vehicles do less useless transport, and thus improving overall order picking efficiency. The disadvantages of the RSS are that the price of the advanced picking AGVs are much higher than a kiva robot, and the application of dense storage racks reduces system scalability.

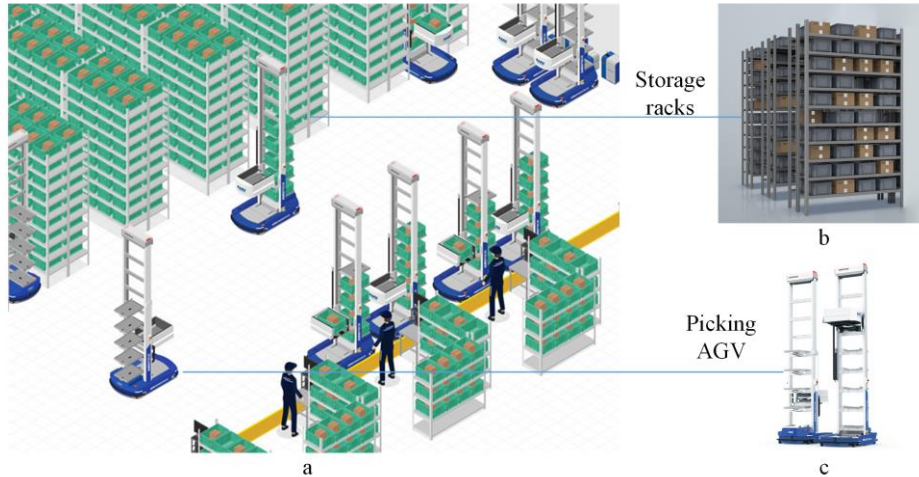

Figure 1: Illustration of a Robot Shuttle System

This paper focuses on the system design and decision optimization of the RSS. For this purpose, an analytical model based on queueing theory is developed for system performance estimation. The analytical model allows us to evaluate system performance under different system configurations and operation decisions with little computation time, which supports warehouse designers and managers to identify optimized system design and make appropriate operation decisions. Furthermore, through numerical experiments, this paper studies the following design and operation decision related research questions:

- (1) How does the batch size of picking AGVs affect system performance?
- (2) How does the number of AGVs affect system performance?

The remainder of the paper is organized as follows: section 2 reviews the literature. Section 3 introduces the robot shuttle system and the system work flow in detail. Section 4 presents the analytical model. Section 5 provides simulation results and section 6 provides numerical experiments and analysis. In section 7, we draw conclusions and provide future research directions.

2 Literature review

The RSS is a new type of order picking system that is derived from RMFS with certain technologies innovation. Due to limited studies on this new system, here we mainly review literatures on RMFSs, which can be divided into two categories, i.e. system design and operational decisions.

Design and analysis of robotic order picking systems is an attractive topic in light of considerable increase in online retails. Enright et al. (2011) described some allocation problems, such as pod storage allocation and order allocation in the RMFS to encourage future researchers to investigate it. Öztürkoğlu et al. (2019) proposed a new design idea, i.e. changing the angle of cross aisle, to find better layouts for RMFS. Simulation is a valuable tool to help evaluating system performance during system design. Lienert et al. (2018) presented a simulation model

for RMFS performance analysis, and the experiment results show a linear correlation between the number of vehicles and the throughput for small number of vehicles. Merschformann et al. (2019) analyzed the pod storage assignment and order assignment problems using discrete event simulation. Hanson et al. (2018) provided insights into the performance of RMFS and how it relates to the system design as well as the implementation context. Researchers also contribute to develop analytical models (e.g. queueing models) to analyze order picking systems. Yuan et al. (2017) built open network models for RMFS which can be used in the design of robotic warehouses. Guan et al. (2018) formulated an integer programming model to study the pod layout problem in RMFS, and a three-stage algorithm on the basis of the Spectral Clustering algorithm is proposed to solve the problem.

As for the operational decisions, Xiang et al. (2018) aimed at minimizing the number of visits of pods, by optimizing system storage assignment and order batching rules, thus reducing the useless traveling of robots in RMFS. Zoning strategies are also popular for optimizing RMFS storage assignment. Lamballais et al. (2020) optimized three decision variables of the RMFS by introducing a cross-class matching multi-class Semi-Open Queueing Network (SOQN). Zou et al. (2017) built a SOQN and a two-phase approximate approach for RMFS performance estimation. They proposed a near optimal order assignment rule based on handling speeds of workstations. Nils et al. (2017) focused on the order processing in a picking station and investigate the batching and sequencing strategies of picking orders. The results show that the optimized order picking allows to more than halve the fleet of robots. The robot allocation is another key factor which may influence performance of RMFS. Zhang et al. (2019) modeled this problem as a resource-constrained project scheduling problem, considering driving behavior of robots. Then a building-blocks-based genetic algorithm is proposed to solve this problem which is validated to be better than several classic and competitive crossover operators.

Although there are plenty of research focusing on RMFS, it is impossible to employ all the research conclusions on RSS, since that the RSS deploys innovative picking robots which works in totally different way. To the best of our knowledge, this paper is the first attempt to study RSS. Taking inspiration from the existing research on RMFS, a queueing network model which includes accurate driving behavior of vehicles is built to evaluate performance of RSS. We combine the batch service of vehicles into the model and investigate how the batch size influence system performance by measuring order throughput time and maximum order throughput capacity. The study of this paper provides guidelines for warehouse developers on optimizing both system design and operational decisions in practical application.

3 Robot shuttle system

This section provides comprehensive description of the robot shuttle system firstly. Then in 3.2.2 the picking process of the RSS is described in detail.

3.1 System description

A top view of the RSS layout is shown in Figure 2. The storage area consists of single-deep, double-sided storage racks, and these storage racks are divided into rectangular blocks by aisles and cross aisles. Each block is formulated by “ $2 \times$ ” storage racks, where 2 is the number of rows of storage racks. The picking area are situated at both ends of the storage area, where workstations and order walls are deployed. There is one picker at a workstation performing order picking, and the picked items are put into corresponding totes on the order wall according to customer orders.

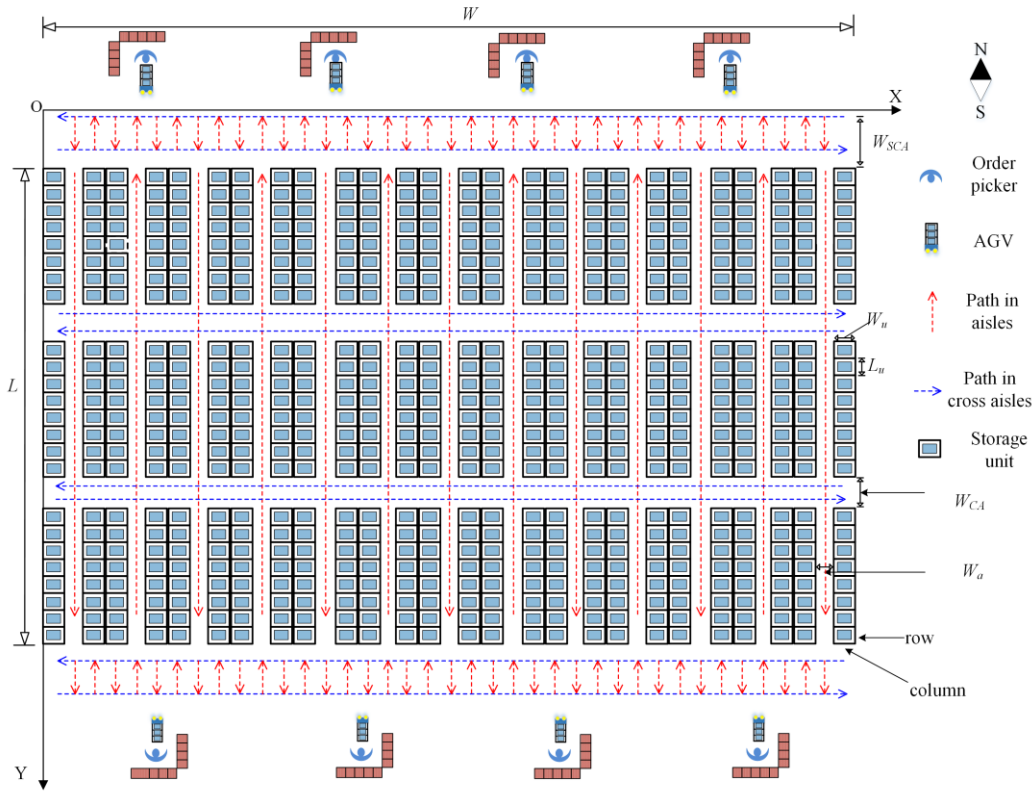

Figure 2: Layout of a Robot Shuttle System

Storage totes are stored on storage racks and each tote is stored at a dedicated storage unit. Each storage unit on racks can be indexed by its row number, column number and layer number, and contains one storage tote with one stock keeping unit. A coordinate system is formulated, where X-axis and Y-axis are arranged along cross aisles and aisles respectively. Then the column number increases with X-axis and the row number increases with Y-axis. The storage unit number can be calculated by

$$N_u = N_R \cdot N_L \cdot (c_u - 1) + N_R \cdot (r_u - 1) + l_u \quad (1)$$

Where N_R and N_L are the total number of rows and layers respectively.

The path planning in the proposed RSS is illustrated in Figure 2. All paths in both aisles and cross aisles are uni-directional to avoid congestion and deadlock. Considering the fact that picking AGVs in an RSS need to frequently travel through different aisles to perform batch service, we design two opposite paths (blue dotted lines) in each cross aisle to decrease travel distance and improve delivering efficiency, while each aisle only has a single path (red dotted lines) to improve space utilization. To simplify the calculation of vehicle moving time, we assume that two paths in a cross aisle are located at the middle of the aisle.

The main notations used in this paper are described in Table 1.

3.2 System workflow

The RSS fulfill order lines in batches, which means that picking AGVs transport a number of totes to a workstation at a time and then the picker picks required products from these totes. Therefore, the workflow is different from that in an RMFS. The main workflow is illustrated in Figure 3 and explained as follows:

Table 1: Notations in the paper

Notations	Description	Notations	Description
N_A, N_{CA}	number of aisles and cross aisles	N_C, N_R, N_L	number of columns, rows and layers
W_u, L_u	width and length of a storage unit(m)	W_A, L_{CA}	width of aisles and cross aisles (m)
W	total width of the storage area (m) $W = N_c \cdot W_u + N_A \cdot W_A$	L	total length of the storage area (m) $L = N_R \cdot L_u + N_{CA} \cdot W_{CA}$
N_{total}	number of storage units $N_{total} = N_R \cdot N_C \cdot N_L$	W_{SCA}	width of cross aisles between workstations and picking area (m)
N_W	Number of workstations	N_{WR}	Number of AGVs that served by one workstation
N	vehicle service batch size	N_l	Order lines in customer orders
τ_p	Picking time of order pickers (s)	τ_{lu}	Vehicles' loading/unloading time (s)
V	Average speed of vehicles (m/s)	τ_t	Turning time of vehicles
R_b	Number of rows in a storage rack block		

- ① The customer orders are split into order lines and wait in the external queues. When an AGV is released from last transport task, a number of order lines are assigned to the idle vehicle following a first-come-first-serve policy.
- ② Move 1: The AGV starts from its current position, and moves to each target tote in sequence, loading all the target totes. The process is described in Figure 3-a.
- ③ Move 2: When all the target totes in the order lines batch are loaded, the vehicle brings them to the claimed workstation, and waits in the queue if the picker is busy. The process is described in Figure 3-b.
- ④ Move 3: The picker picks up required products from totes on the vehicles, following a first-come first-serve policy. The picking time is stochastic, and we assume that it follows a general distribution, i.e. $\tau_p \sim U[a, b]$. After all the totes on the vehicle are handled, the vehicle transports the totes back to storage area, and the totes will be stored at their original storage units. The vehicle firstly moves from workstation to the first target storage unit, see Figure 3-c.
- ⑤ Move 4: Then the vehicle moves to each target tote in sequence, unloading all the target totes. The process is illustrated in Figure 3-d.
- ⑥ The main assumptions and operational rules are listed as follows: (1) In the RSS, we assume that retrieval task occurs at a random storage unit. (2) This study only considers order picking process while replenishment process is not considered, since the order picking strictly relates to service level. Thus we assume that there are always sufficient products to satisfy incoming order line, and no product shortage happens. (3) The picking AGVs are served by their dedicated workstations. (4) Congestion and deadlock may never happen due to the uni-directional paths applied. (5) The customer orders with different sizes arrive following a Poisson distribution with parameter λ . (6) The number of order

lines in an order is stochastic and follows a uniform distribution, $N_l \sim U[n_{min}, n_{max}]$. (7) Vehicles' loading/unloading time τ_{lu} is constant. (8) Vehicles transport a fixed number of totes, i.e. the batch size N is a constant.

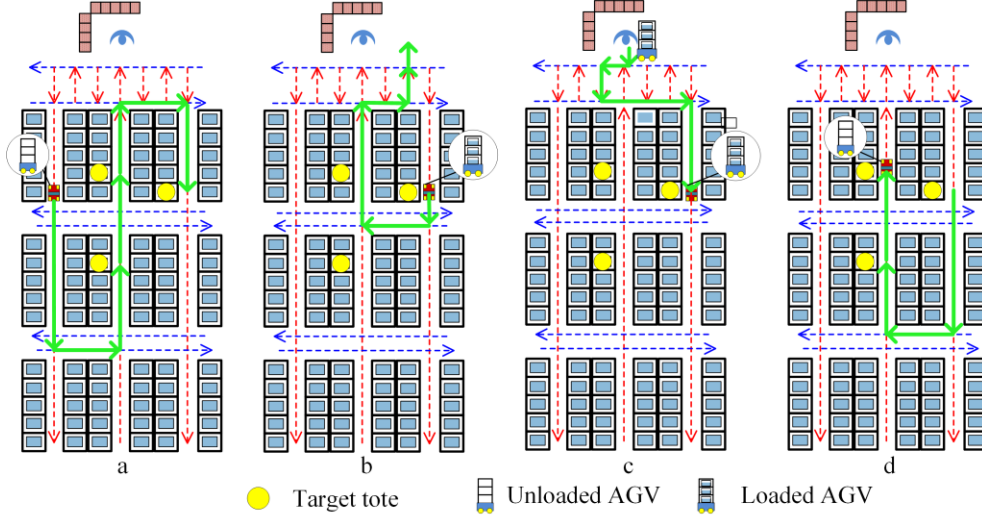

Figure 3: Illustrating the Main Workflow in the Robot Shuttle System

4 Analytical model for RSS performance estimation

Section 4.1 provides methods to calculate service time of vehicles. Section 4.2 presents a SOQN to estimate system performance. In section 4.3, a solution to solve the SOQN is described in detail.

4.1 Service time of vehicles

During the whole order picking process, vehicles' movements consist of four part, i.e. move 1 to move 4. Move 1 and move 3 are similar, which describe the travel between a workstation and an arbitrary storage unit. Move 2 and move 4 are also similar, which describe the travel among different storage units and the loading/unloading of vehicles. Since the loading/unloading time is constant, we only need to calculate the travel times of vehicles.

Firstly, we should know the location of each workstation and storage unit. As for the workstations, this study only considers the ones located on the northside of the storage area. We assume that the workstations are located on X-axis, and the index $i \in [1, N_w]$ increases along the X-axis. Then the coordinates of the i^{th} workstation can be denoted as:

$$(x_w, y_w) = \left(\left(i - \frac{1}{2} \right) \cdot \frac{W}{N_L}, 0 \right) \quad (2)$$

As for the storage units, since vehicles only move on the ground and perform loading/unloading on paths of aisles, the coordinates of a storage unit can be calculated by (3) according to the aisle number a_u and the row number r_u .

$$(x_u, y_u) = \left((2a_u - 1) \cdot W_u + \left(a_u - \frac{1}{2} \right) \cdot W_A, W_{CA} + \left(r_u - \frac{1}{2} \right) \cdot L_u \right) \quad (3)$$

In particular, we use y_b to denote the index of storage rack block that a storage unit belongs to along the Y-axis. y_b can be calculated according to r_u by (4):

$$y_b = \frac{r_u}{R_b} + 1 \quad (4)$$

Then we can calculate the travel time of vehicles, including the travel time from a workstation to a storage unit, and the travel time from a storage unit to another storage unit.

4.1.1 Travel time from a workstation to a storage unit

Assume that the vehicle starts from a storage unit (a_u, r_u, y_b) to the i^{th} workstation, the travel time is denoted by $\tau_{sw,i}$.

(1) If the path direction in the aisle is south, then the travel is composed of four movements.

① The vehicle moves to the nearest cross aisle along the path, the distance can be calculated by (5).

$$d_1 = \frac{W_{ca}}{2} + (y_b - r_u + \frac{1}{2}) \cdot L_u \quad (5)$$

② The vehicle moves towards the target workstation to the adjacent aisle, the distance is:

$$d_2 = W_{ca} + 2W_u \quad (6)$$

③ The vehicle moves to the cross aisle between the storage area and the picking area. The travel distance is:

$$d_3 = (y_b \cdot r_b - \frac{1}{2}) \cdot L_u + (y_b - 1) \cdot W_{ca} + \frac{W_{sca}}{2} \quad (7)$$

④ The vehicle moves to the workstation along the cross aisle, and the travel distance is:

$$d_4 = \left| x_{w,i} - x_u \right| - (W_a + 2W_u) \quad (8)$$

Then the total travel time can be calculated by equation (9).

$$\tau_{sw,i} = \frac{d_1 + d_2 + d_3 + d_4}{V} \quad (9)$$

(2) If the path direction in the aisle is north, then the travel is composed of two movements.

① The vehicle moves to the cross aisle between the storage area and the picking area. The travel distance is:

$$d_1 = (r_u - \frac{1}{2}) \cdot L_u + (y_b - 1) \cdot W_{ca} + \frac{W_{sca}}{2} \quad (10)$$

② The vehicle moves to the workstation along the cross aisle, and the travel distance is:

$$d_2 = (r_u - \frac{1}{2}) \cdot L_u + (y_b - 1) \cdot W_{ca} + \frac{W_{sca}}{2} \quad (11)$$

Then the total travel time can be calculated by equation (12).

$$\tau_{sw,i} = \frac{d_1 + d_2}{V} \quad (12)$$

4.1.2 Travel time between two storage units

Assume that the vehicle starts from a storage unit $(a_{u,1}, r_{u,1}, y_{b,1})$ to another storage unit $(a_{u,2}, r_{u,2}, y_{b,2})$, the travel time is denoted by τ_{ss} .

(1) When $a_{u,1} = a_{u,2}$, then the travel distance from $(a_{u,1}, r_{u,1}, y_{b,1})$ to $(a_{u,2}, r_{u,2}, y_{b,2})$ is:

$$d_1 = |r_{u,1} - r_{u,2}| \cdot L_u + |y_{b,1} - y_{b,2}| \cdot W_{ca} \quad (13)$$

Then the total travel time can be calculated by equation (14).

$$\tau_{ss} = \frac{d_1}{V} \quad (14)$$

(2) When $a_{u,1} \neq a_{u,2}$, if the path direction in $a_{u,1}$ is south and the path direction in $a_{u,2}$ is north, then the travel is composed of three movements.

① If $y_{b,1} < y_{b,2}$, then the vehicle moves to the nearest cross aisle on the south of block $y_{b,2}$; If $y_{b,1} \geq y_{b,2}$, then the vehicle moves to the nearest cross aisle along the path in $a_{u,1}$.

$$d_1 = \begin{cases} \left((y_{b,1} + |z_1 - z_2|) \cdot R_b - r_{u,1} + \frac{1}{2} \right) \cdot L_u & y_{b,1} < y_{b,2} \\ + \left(\frac{1}{2} + |y_{b,1} - y_{b,2}| \right) \cdot W_{ca}, & \\ \left(y_{b,1} \cdot R_b - r_{u,1} + \frac{1}{2} \right) \cdot L_u + \frac{W_{ca}}{2}, & y_{b,1} \geq y_{b,2} \end{cases} \quad (15)$$

② The vehicle moves to $a_{u,2}$, and the travel distance is:

$$d_2 = |x_{u,1} - x_{u,2}| \quad (16)$$

③ The vehicle moves to the location of the target storage unit along $a_{u,2}$, and the travel distance is:

$$d_3 = \begin{cases} \left(y_{b,1} \cdot R_b - r_{u,2} + \frac{1}{2} \right) \cdot L_u + \frac{W_{ca}}{2} & y_{b,1} < y_{b,2} \\ \left(y_{b,1} \cdot R_b - r_{u,2} + \frac{1}{2} + |y_{b,1} - y_{b,2}| \cdot R_b \right) \cdot L_u & \\ + \left(\frac{1}{2} + |y_{b,1} - y_{b,2}| \right) \cdot W_{ca}, & y_{b,1} \geq y_{b,2} \end{cases} \quad (17)$$

Then the total travel time can be calculated by equation (18).

$$\tau_{ss} = \frac{d_1 + d_2 + d_3}{V} \quad (18)$$

(3) When $a_{u,1} \neq a_{u,2}$, if the direction of paths in $a_{u,1}$ and $a_{u,2}$ are both south and $y_{b,1} < y_{b,2}$, then the travel is composed of three movements.

- ① The vehicle moves to the nearest cross aisle along the path in $a_{u,1}$, and the travel distance is:

$$d_1 = \left(y_{b,1} \cdot R_b - r_{u,1} + \frac{1}{2} \right) \cdot L_u \quad (19)$$

- ② The vehicle moves to $a_{u,2}$, and the travel distance is:

$$d_2 = |x_{u,1} - x_{u,2}| \quad (20)$$

- ③ The vehicle moves to the location of the target storage unit along $a_{u,2}$, and the travel distance is:

$$d_3 = \left(r_{u,2} - \frac{1}{2} + (|y_{b,1} - y_{b,2}| - y_{b,2}) \cdot R_b \right) \cdot L_u + \frac{W_{ca}}{2} \quad (21)$$

Then the total travel time can be calculated by equation (22).

$$\tau_{ss} = \frac{d_1 + d_2 + d_3}{V} \quad (22)$$

- (4) When $a_{u,1} \neq a_{u,2}$, if the direction of paths in $a_{u,1}$ and $a_{u,2}$ are both south and $y_{b,1} \geq y_{b,2}$, then the travel is composed of five movements.

- ① The vehicle moves to the nearest cross aisle along the path in $a_{u,1}$, and the travel distance is:

$$d_1 = \left(y_{b,1} \cdot R_b - r_{u,1} + \frac{1}{2} \right) \cdot L_u \quad (23)$$

- ② The vehicle moves towards $a_{u,2}$ to the adjacent aisle, and the distance is:

$$d_2 = W_a + 2W_u \quad (24)$$

- ③ The vehicle moves to the nearest cross aisle on the north of block $y_{b,2}$, and the travel distance is:

$$d_3 = (|y_{b,1} - y_{b,2}| + 1) \cdot (W_{ca} + R_b \cdot L_u) \quad (25)$$

- ④ The vehicle moves to $a_{u,2}$, and the travel distance is:

$$d_4 = (|y_{b,1} - y_{b,2}| - 1) \cdot (W_a + 2W_u) \quad (26)$$

- ⑤ The vehicle moves to the location of the target storage unit along $a_{u,2}$, and the travel distance is:

$$d_5 = \left(r_{u,2} - (y_{b,2} - 1) \cdot R_b - \frac{1}{2} R_b \right) \cdot L_u + \frac{W_{ca}}{2} \quad (27)$$

Then the total travel time can be calculated by equation (28).

$$\tau_{ss} = \frac{d_1 + d_2 + d_3 + d_4 + d_5}{V} \quad (28)$$

- (5) When $a_{u,1} \neq a_{u,2}$, if the path direction in $a_{u,1}$ is south and the path direction in $a_{u,2}$ is north,

then the travel is composed of three movements.

- ① If $y_{b,1} > y_{b,2}$, then the vehicle moves to the nearest cross aisle on the north of block $y_{b,2}$; If $y_{b,1} \leq y_{b,2}$, then the vehicle moves to the nearest cross aisle along the path in $a_{u,1}$. The travel distance can be calculated by (29).

$$d_1 = \begin{cases} \left(r_{u,1} - (y_{b,1} - 1 + |y_{b,1} - y_{b,2}|) \cdot R_b - \frac{1}{2} \right) \cdot L_u & y_{b,1} < y_{b,2} \\ + \left(\frac{1}{2} + |y_{b,1} - y_{b,2}| \right) \cdot W_{ca}, & \\ \left(r_{u,1} - (y_{b,1} - 1) \cdot R_b - \frac{1}{2} \right) \cdot L_u + \frac{W_{ca}}{2}, & y_{b,1} \geq y_{b,2} \end{cases} \quad (29)$$

- ② The vehicle moves to $a_{u,2}$, and the travel distance is:

$$d_2 = |x_{u,1} - x_{u,2}| \quad (30)$$

- ③ The vehicle moves to the location of the target storage unit along $a_{u,2}$, and the travel distance is:

$$d_3 = \begin{cases} \left(r_{u,2} - (y_{b,2} - 1) \cdot R_b - \frac{1}{2} \right) \cdot L_u + \frac{W_{ca}}{2}, & y_{b,1} > y_{b,2} \\ \left(r_{u,2} + \left(|y_{b,1} - y_{b,2}| - y_{b,1} + 1 - \frac{1}{2} \right) \cdot R_b - \frac{1}{2} \right) \cdot L_u & \\ + \left(\frac{1}{2} + |y_{b,1} - y_{b,2}| \right) \cdot W_{ca} & y_{b,1} \geq y_{b,2} \end{cases} \quad (31)$$

Then the total travel time can be calculated by equation (32).

$$\tau_{ss} = \frac{d_1 + d_2 + d_3}{V} \quad (32)$$

- (6) When $a_{u,1} \neq a_{u,2}$, if the direction of paths in $a_{u,1}$ and $a_{u,2}$ are both south and $y_{b,1} > y_{b,2}$, then the travel is composed of three movements.

- ① The vehicle moves to the nearest cross aisle along the path in $a_{u,1}$, and the travel distance is:

$$d_1 = \left(r_{u,1} - (y_{b,1} - 1) \cdot R_b - \frac{1}{2} \right) \cdot L_u + \frac{W_{ca}}{2} \quad (33)$$

- ② The vehicle moves to $a_{u,2}$, and the travel distance is:

$$d_2 = |x_{u,1} - x_{u,2}| \quad (34)$$

- ③ The vehicle moves to the location of the target storage unit along $a_{u,2}$, and the travel distance is:

$$d_3 = \left((|y_{b,1} - y_{b,2}| + y_{b,1} - 1) \cdot R_b - r_{u,2} + \frac{1}{2} \right) \cdot L_u + \left(|y_{b,1} - y_{b,2}| - \frac{1}{2} \right) \cdot W_{ca} \quad (35)$$

Then the total travel time can be calculated by equation (36).

$$\tau_{ss} = \frac{d_1 + d_2 + d_3}{V} \quad (36)$$

(7) When $a_{u,1} \neq a_{u,2}$, if the direction of paths in $a_{u,1}$ and $a_{u,2}$ are both south and $y_{b,1} \leq y_{b,2}$, then the travel is composed of five movements.

① The vehicle moves to the nearest cross aisle along the path in $a_{u,1}$, and the travel distance is:

$$d_1 = \left(r_{u,1} - (y_{b,1} - 1) \cdot R_b - \frac{1}{2} \right) \cdot L_u + \frac{W_{ca}}{2} \quad (37)$$

② The vehicle moves towards $a_{u,2}$ to the adjacent aisle, and the distance is:

$$d_2 = W_a + 2W_u \quad (38)$$

③ The vehicle moves to the nearest cross aisle on the south of block $y_{b,2}$, and the travel distance is:

$$d_3 = (|y_{b,1} - y_{b,2}| + 1) \cdot (W_{ca} + R_b \cdot L_u) \quad (39)$$

④ The vehicle moves to $a_{u,2}$, and the travel distance is:

$$d_4 = (|y_{b,1} - y_{b,2}| - 1) \cdot (W_a + 2W_u) \quad (40)$$

⑤ The vehicle moves to the location of the target storage unit along $a_{u,2}$, and the travel distance is:

$$d_5 = \left(y_{b,2} \cdot R_b - r_{u,2} + \frac{1}{2} \right) \cdot L_u + \frac{W_{ca}}{2} \quad (41)$$

Then the total travel time can be calculated by equation (42).

$$\tau_{ss} = \frac{d_1 + d_2 + d_3 + d_4 + d_5}{V} \quad (42)$$

4.2 SOQN for the robot shuttle system

The main objective of the paper is to formulate an analytical model for the RSS to estimate system performance, which can help us optimize system design and operation decision related parameters. Thus we construct a semi-open queueing network for the RSS, see Figure 4, and the SOQN model takes the batch service of vehicles into consideration. In the network, the order lines are assumed as customers. Since that the workstations work independently, we analyze the performance of a single workstation in isolation, and the analysis can be extended to other workstations similarly.

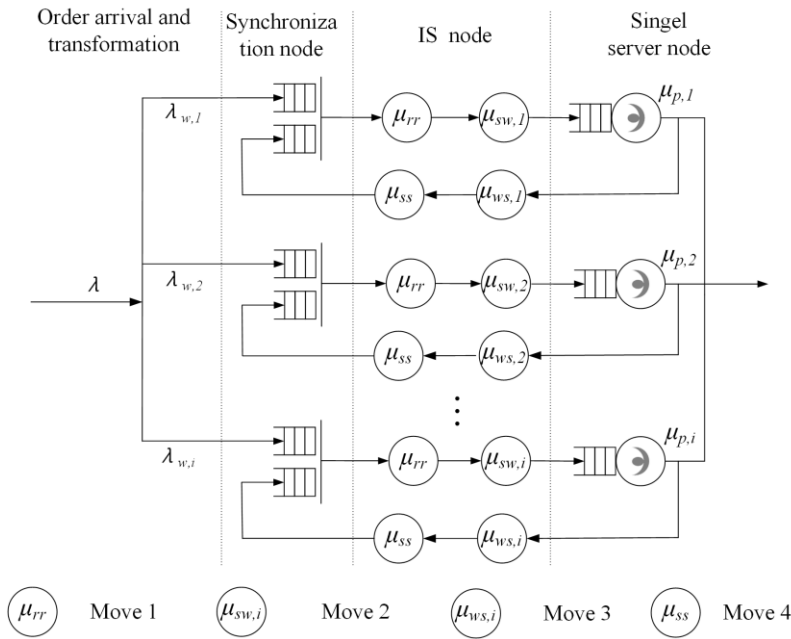

Figure 4: The Semi Open Queueing Network for the Robot Shuttle System

There are three kinds of server nodes in the proposed SOQN:

(1) Synchronization node.

When customer orders arrive at the system, they are split into individual order lines first, and then these order lines are paired with vehicles in batches. These procedures are implemted in the synchronization node, which consists of two queues, the queue of order lines Q_{ol} and the queue of vehicles Q_v .

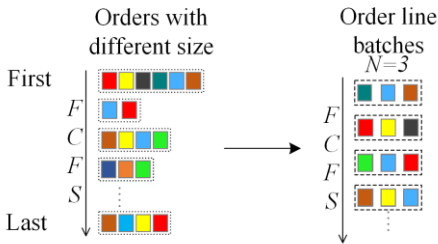

Figure 5: Illustrating the Transformation of Orders with Different Size to Order line batches

To analyze the performance of the synchronization node, we need to analyze the order arrival process first. As shown in Figure 5, the stream of arriving orders of different sizes are transformed to a stream of order line batches with batch size N . Assume that orders arrive at each workstation with identical probability, then the arrival rate of orders to the i^{th} workstation is $\lambda_{w,i} = \lambda / N_w$. Therefore, the arrival rate of order line batches to a workstation can be computed by (43).

$$\lambda_{b,i} = \frac{\lambda_{w,i} \cdot \overline{N}_l}{N} \tag{43}$$

Then the coefficient of variation $CV_{b,i}^2$ of interarrival time of order line batches with batch size N can be derived through the method by Bolch et al. (2006):

$$CV_{b,i}^2 = \frac{\overline{N}_l \cdot (CV_{w,i}^2 + CV_{N_l}^2)}{N} \quad (44)$$

Where $CV_{w,i}^2$ is the coefficient of variation of interarrival time of orders with different sizes, and $CV_{N_l}^2$ is the coefficient of variation of the orders' size.

(2) Infinite server (IS) node

When a batch of order lines are paired with an idle vehicle at the synchronization node, the vehicle can also be regarded as a customer. All the moves of the vehicle can be modelled as IS nodes since vehicles do not need to wait in any queue before moving, i.e. move 1, 2, 3, 4 are modelled by IS node u_{rr} , $u_{sw,i}$, $\mu_{ws,i}$, μ_{ss} respectively. In the model, the number of servers at an IS node are set as equal to the number of vehicles. The distribution of the service time of the IS nodes can be calculated based on the analysis in section 4.1, including the first and second moments of the service time.

(3) Single server node

At the workstation, vehicles wait in the queue and the order picker picks products from totes on the vehicles. Since there is only one picker at each workstation, the workstations are modelled as single server nodes. According to the distribution of the picking time, we can also calculate the first and second moments of the picking time.

The proposed SOQN model is analyzed using the solution procedure proposed by Buitenhek et al. in section 2.2. The maximum throughput TH_b , average throughput time OT_b and external queue L_o of the order line batches can be obtained. Then the maximum throughput TH_l , average throughput time OT_l and external queue $L_{q,l}$ of the order lines are calculated as follows:

$$TH_l = N \cdot TH_b \quad (45)$$

$$OT_l = OT_b \quad (46)$$

$$L_{q,l} = N \cdot L_o + \frac{N-1}{2} \quad (47)$$

Note that in (46), the first term represents the order lines in the L_o batches of the external queue, and the second term is the average number of order lines which are waiting to be combined into a batch.

5 Simulation validation

The discrete event simulation model is built with Arena (version 14.7), which complies with the real implementation of the RSS. The simulation model is assumed to conduct an infinite-horizon simulation, which can obtain a steady-state behavior analysis of the proposed robot shuttle system.

The simulation starts from an empty and idle state. In the simulation, the warm-up period of 10 hours is specified following the method by Welch (1983). The data collected during the warm-up period is disregarded to mitigate the presence of initialization bias. According to the rule of thumb in Banks et al. (2001), the simulation length is set as 100 hours, which is 10 times of the warm-up period. For each simulation, 30 replications are implemented.

The parameters for the simulation experiments are shown in Table 1. In the experiments, 9 scenarios are examined as a combination of three values of N and three values of N_{WR} , and three different order retrieval demand rates are set according to three different values of N_{WR} , to make the vehicle utilization no less than 60%.

N_{total}	N_C	N_R	N_L	N_{CA}	N_A	W_u	L_u	W_A	N_{WR}
16800	30	80	7	7	15	0.7 m	0.6 m	1 m	8, 10, 12
W_{CA}	W_{SCA}	τ_P	τ_{lu}	V_m	k_a	τ_t	N_l	R_b	N
2 m	2 m	$U[6s,10s]$	4s	2.1 m/s	3 m/s^3	1s	$U[1,5]$	10	3, 4, 5

The results are shown in Table 2. The system performance estimation results of simulation and analytical model are compared under 9 scenarios. The results show that, the deviation between analytical model and simulation are relatively low, which means that the proposed SOQN model can provide accurate estimation of system performance. Note that the OT_l estimated by the analytical model is always lower than that given by the simulation. This is mainly because that the time to combine order lines into batches is not considered in the analytical model. Besides, we can see that the system performance is affected by the service batch size N and the number of vehicles N_{WR} . Therefore, we investigate the influence of N and N_{WR} through numerical experiments in the next section.

Table 1: Estimation Results Comparison between Simulation (S) and Analytical Model (A)

N	N_{WR}	λ	OT_l		$L_{q,l}$		ρ_r		ρ_w	
			A	S	A	S	A(%)	S(%)	A(%)	S(%)
3	8	80	271.9	278.3	1.78	1.55	72.3	72.0	61.4	61.3
	10	100	291.6	297.1	1.99	1.72	77.7	77.9	76.4	76.3
	12	120	332.4	340.3	3.22	3.04	86.1	86.3	89.6	89.7
4	8	80	339.4	347.7	2.2	1.83	68.5	68.2	61.5	61.4
	10	100	368.2	375.4	2.38	2.06	74.5	75.1	76.6	76.6
	12	120	425.2	439.8	3.62	3.35	84.2	84.7	89.9	89.8
5	8	80	417.9	423.5	2.79	2.08	67.6	67.5	61.5	61.7
	10	100	454.7	470.1	3	2.39	73.8	74.1	76.6	76.5
	12	120	526.9	548.6	4.47	3.91	83.7	83.4	90	90.2

6 Numerical experiments

The number of vehicles N_{WR} should be determined during the system design phase, and the service batch size N is related to picking operation. We vary N and N_{WR} to study how they affect system performance, and five system performance measures are analyzed, namely: maximum throughput capacity TH_l , average throughput time OT_l , and external queue $L_{q,l}$ with respect to order lines, and the utilization of vehicles ρ_r and the picker ρ_w . The experimental scenario and basic parameters are the same as the simulation. In the experiment, two different

order retrieval demand rates are analyzed, namely: $\lambda_{w,i} = 40$ orders/hour and $\lambda_{w,i} = 80$ orders/hour. In each case, five different N values (i.e. $N = 1, 2, 3, 4, 5$) combined with 8 different N_{WR} values (i.e. $N_{WR} = 5, 6, 7, 8, 9, 10, 11, 12$) are considered.

According to Lamballais et al. (2017), the maximum order throughput capacity is independent of order retrieval demand level but depends on the system design and operational decisions. We analyze the TH_b of the robot shuttle system first, by removing the synchronization node from the proposed SOQN model, and then the TH_l can be derived from TH_b . The results are shown in

Figure 6.

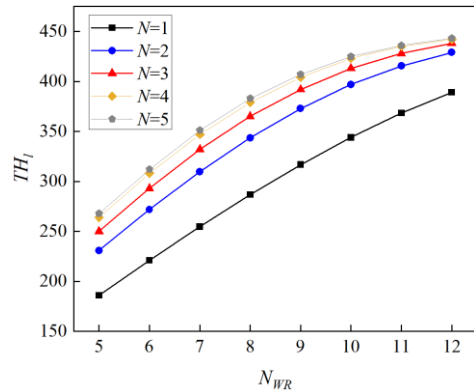

Figure 6: Illustration of TH_l Varying with N and N_{WR}

From the results we learn that, the TH_l increases with both N and N_{WR} . However, when the number of robots N_{WR} or the service batch size N exceeds a certain high level, the TH_l increases slightly with N_{WR} or N due to the limitation of the picking efficiency of the picker.

Therefore, warehouse designers should choose optimized values for N_{WR} and N to avoid over-productivity of the vehicles, which may help reduce overall system costs.

Then we analyze how the OT_l and the $L_{q,l}$ are affected by the N_{WR} and N . The results are shown in Figure 7 ($\lambda_{w,i} = 40$) and Figure 8 ($\lambda_{w,i} = 80$), where the utilization of vehicles ρ_r and the picker ρ_w are also presented. Three main conclusions we can draw from the results are:

- 1) When $\lambda_{w,i} = 40$, the utilization of vehicles ρ_r is relatively low. When $\lambda_{w,i} = 80$, the ρ_r is still maintained at a low level when a large number of vehicles are deployed, while the ρ_r is relatively high when there are fewer vehicles in the system.
- 2) From the results in the two figures, we learn that when ρ_r is maintained at a low level, both the OT_l and the $L_{q,l}$ are short and converge to certain values respectively with N_{WR} increasing. When ρ_r is high, increasing N_{WR} can decrease the OT_l and the $L_{q,l}$ effectively.

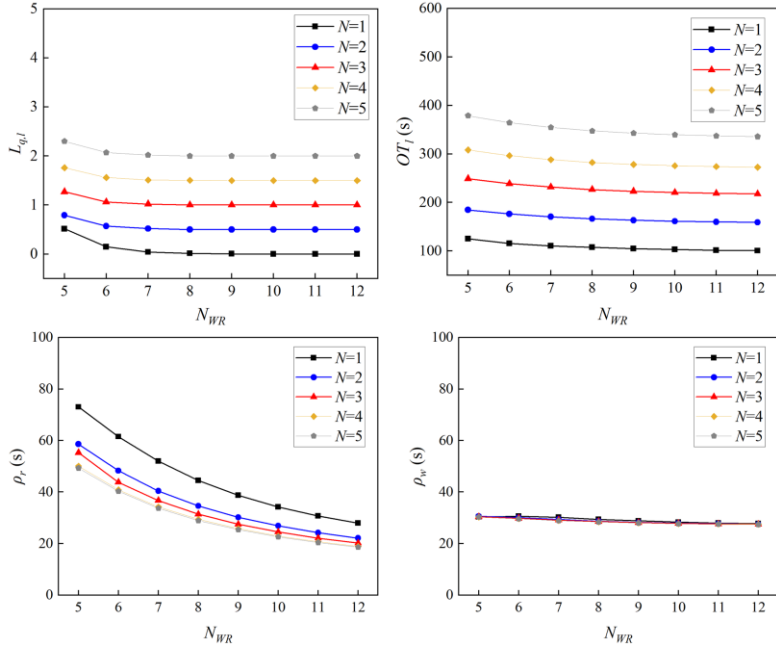

Figure 7: Illustration of System Performance Varying with N and N_{WR} ($\lambda_{w,i} = 40$)

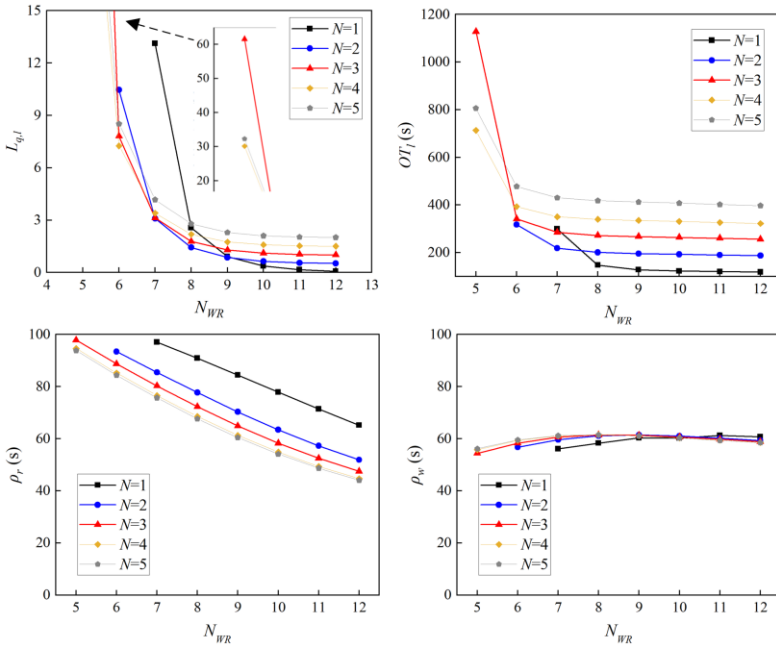

Figure 8: Illustration of System Performance Varying with N and N_{WR} ($\lambda_{w,i} = 40$)

- 3) When ρ_r is low, the main cause of external queue is that order lines need to be combined into a batch. According to the second term in formula (46), the $L_{q,i}$ will increase with N . We can see that the results with respect to $L_{q,i}$ validate the above analysis. The OT_i also increases with N since that the vehicles and the picker need to handle more order lines in a handling cycle.

When ρ_r is high, increasing N may improve the operational efficiency to a certain extent, which can decrease $L_{q,l}$, as well as the OT_l . If N is very low, (e.g. when $\lambda_{w,i} = 80$, $N_{WR} = 5$, and $N = 1$), the system cannot even reach a steady state.

Overall, increasing both N and N_{WR} reasonably according to order retrieval demand level can improve system performance. However, excessive increase of N_{WR} may cause over-productivity of vehicles. Similarly, over-increase of N may increase OT_l considerably and thus cause severe delay of order delivery.

7 Conclusions

In this study, we focus on the performance analysis of robot shuttle system. First, a semi open queueing network model is developed to provide accurate performance estimation for the RSS. The effectiveness of the analytical model is confirmed by simulation experiments. The main implication of the analytical model is to help warehouse developers evaluate system performance under different system configurations efficiently. The study also provides guidelines for warehouse designers and managers on how to identify an appropriate service batch size and a proper number of AGVs within a workstation, which can avoid over-productivity of vehicles and lower system costs. In the future research, the impact of rack layouts on system performance may be taken into consideration.

References

- Banks J., J. S. C. II, B. L. Nelson, and D. M. Nicol (2001): *Discrete-event system simulation /-3rd edn.* Prentice Hall, 2001.
- Bolch G., S. Greiner, H. De Meer, and K. S. Trivedi (2006): *Queueing networks and Markov chains: modeling and performance evaluation with computer science applications*, 2ed ed. New Jersey: John Wiley & Sons, 2006.
- Baker P. and Z. Halim (2007): "An exploration of warehouse automation implementations: cost, service and flexibility issues," *Supply Chain Management: An International Journal*, vol. 12, no. 2, pp. 129-138, 20 March 2007.
- Boysen N., D. Briskorn, and S. Emde (2017): "Parts-to-picker based order processing in a rack-moving mobile robots environment," *Eur J Oper Res*, vol. 262, no. 2, 2, pp. 550-562, 2017.
- Enright J. J. and P. R. Wurman (2011) "Optimization and coordinated autonomy in mobile fulfillment systems," in *Proceedings of the 9th AAAI Conference on Automated Action Planning for Autonomous Mobile Robots*, San Francisco, California, USA, 2011, 2908681: AAAI Press, pp. 33-38.
- Guan M. and Z. Li (2018): "Pod Layout Problem in Kiva Mobile Fulfillment System Using Synchronized Zoning," *Journal of Applied Mathematics and Physics*, vol. 06, no. 12, pp. 2553-2562, 2018.

- Hanson R., L. Medbo, and M. I. Johansson (2018): "Performance Characteristics of Robotic Mobile Fulfillment Systems in Order Picking Applications," *IFAC-PapersOnLine*, vol. 51, no. 11, 11, pp. 1493-1498, 2018.
- Lamballais T., D. Roy, and M. B. M. De Koster (2017): "Estimating performance in a Robotic Mobile Fulfillment System," *Eur J Oper Res*, vol. 256, no. 3, 3, pp. 976-990, Feb 2017.
- Lienert T., T. Staab, C. Ludwig, and J. Fottner (2018): "Simulation-based Performance Analysis in Robotic Mobile Fulfillment Systems," in *Proceedings of the 8th International Conference on Simulation and Modeling Methodologies, Technologies and Applications*, Porto, Portugal, 2018: SciTePress, 2018, pp. 383-390.
- Lamballais T., D. Roy, and R. B. M. De Koster (2019): "Inventory allocation in robotic mobile fulfillment systems," *IISE Transactions*, vol. 52, no. 1, pp. 1-17, 2020/01/02 2020.
- Merschformann M., T. Lamballais, M. B. M. D. Koster, and L. Suhl, "Decision Rules for Robotic Mobile Fulfillment Systems," *Operations Research Perspectives*, vol. 6, pp. 100-128, 2019.
- Öztürkoğlu Ö. and A. Mağara (2019): "A New Layout Problem for Order-Picking Warehouses," in *Proceedings of the 9th international conference on industrial engineering and operations management*, Bangkok, Thailand, 2019, pp. 1047-1058.
- Welch P. D. (1983): "The statistical analysis of simulation results," *The computer performance modeling handbook*, vol. 22, pp. 268-328, 1983.
- Xiang X., C. Liu, and L. Miao (2018): "Storage assignment and order batching problem in Kiva mobile fulfillment system," *Engineering Optimization*, vol. 50, no. 11, 11, pp. 1941-1962, 2018.
- Yuan Z. and Y. Y. Gong (2017): "Bot-In-Time Delivery for Robotic Mobile Fulfillment Systems," *IEEE Transactions on Engineering Management*, vol. 64, no. 1, 1, pp. 83-93, 2017.
- Zhang J., F. Yang, and X. Weng (2019): "A Building-Block-Based Genetic Algorithm for Solving the Robots Allocation Problem in a Robotic Mobile Fulfillment System," *Mathematical Problems in Engineering*, vol. 2019, pp. 1-15, 2019.